



Evaporation technologies in the pulp industry using the sulfite process

Given today's competitive landscape and strained energy situation, the pulp industry is faced with the task of maximizing its potential in the best possible way.

In this **White Paper**, you will learn which evaporation technologies are used for the concentration of sulfite waste liquors and their advantages and disadvantages. Furthermore, we discuss the various possibilities for realizing energy potential and the profitable use of waste heat in sulfite pulp mills. Another chapter is devoted to recovery of valuable products from sulfite waste liquor.

WHITE PAPER: Evaporation technology sulfite pulp mill

Challenge: Pollution & potential utilization

The sulfite process places high demands on evaporation plants due to heavy fouling. In particular, the cleanability of the heat exchangers plays an essential role here. In addition, especially with existing plant concepts, there is often a high potential for energy savings and waste heat utilization, which can be rapidly implemented. Also, valuable by-streams from the sulfite process have hardly been used.

Solution: State-of-the-art technologies

Today's state of the art in sulfite pulp mills are plate falling film evaporators, characterized by good cleanability and high efficiency with low energy consumption. Furthermore, the considerable saving potential is achievable by applying different technologies and processes, and side streams from the sulfite process can be supplied for commercial use. As far as waste heat utilization goes, as well as the internal use of surplus heat, the extraction of previously unused low-temperature waste heat into local and district heating networks is an attractive option.

Benefits: Specialist for plants in the sulfite pulp industry

GIG Karasek is one of the leading central European manufacturers of evaporation plants for the pulp and regenerated fiber industry. Especially in the field of plate falling film evaporators. We have been leading the way for many decades, offering the best available technologies (BAT) to best meet the industry's requirements in terms of energy efficiency. There are various solutions available for recovering valuable products from sulfite waste liquor, all the way to testing and developing new processes.

Content

SULFITE PROCESS: COMPARISON OF EVAPORATOR TYPES	5
1. Rising film evaporator	6
2. Forced circulation evaporator	7
3. Tube falling film evaporator	9
4. Spray falling film evaporator	11
5. State-of-the-Art: Plate falling film evaporator	12
Conclusion: Evaporator types in the pulp industry	15
CLEANING OF EVAPORATION PLANTS: THE FOLLOWING MUST BE TAKEN INTO ACCOUNT IN THE SULFITE PROCESS	16
Cleaning the medium side (gypsum))	16
Cleaning the heating steam side (Furfural)	17
Comparison of cleaning properties of tube and plate falling film evaporators	18
Reduction of deposits through the proper design	19
Conclusion: Cleaning evaporation plants in the sulfite process	19
INNOVATIVE USE OF SIDE STREAMS	20
The sulfite process in the paper and pulp industry	20
Added value through the use of by-products	21
Increased diversification in sulfite pulp mills	21
The biorefinery concept is becoming increasingly important	22
Conclusion: By-products from the sulfite process	28
SAVING ENERGY: MEE AND MVR IN COMPARISON	29
Multiple effect evaporation plants (MEE)	29
Evaporation plants with mechanical vapor recompression (MVR)	33
Upgrading existing multistage plants	36
MVR plant versus multiple effect plant	37
Conclusion: Saving energy	38

USE CASE: WORLD'S LARGEST MVR-PULP MILL SAPPI SAICCOR	39
The Vulindlela project	39
Project management within a „Postage Stamp“ area“	40
Conclusion: Mechanical Vapor Recompression in the pulp industry	43
INDUSTRIAL WASTE HEAT UTILIZATION IN SULFITE PULP MILLS	44
What to do with excess heat?	44
Efficient utilization of waste heat through cascade utilization	45
How are waste heat sources evaluated?	46
In-house waste heat utilization	48
External use: From waste heat to local and district heating	51
Conclusion: Industrial waste heat utilization in the pulp industry	53

Sulfite process: Comparison of evaporator types

Various technologies and evaporator systems have been developed over the past decades to concentrate sulfate liquors and to solve the problem of fouling as effectively as possible.

Plate falling film evaporators are currently the leading technology in this field. At the same time, older evaporator types are still widely used.

In the following, we show the principle of the different technologies and their advantages and disadvantages in dealing with the challenges in the sulfite process.

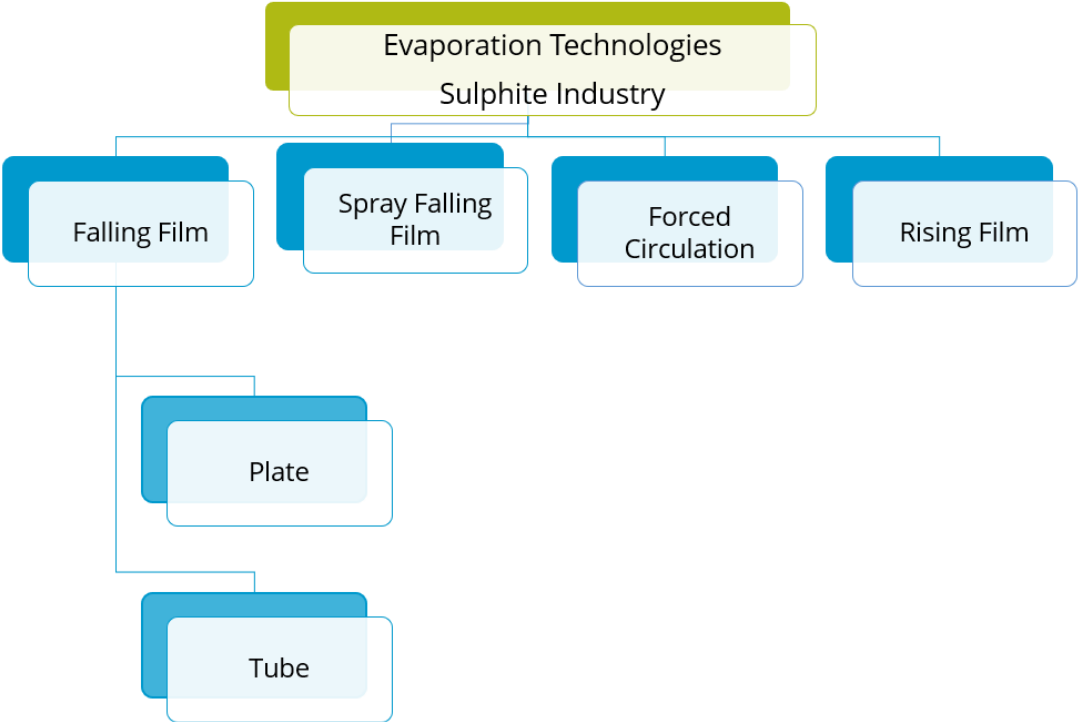

1. Rising film evaporator

Rising film evaporators are part of the first evaporator generation in the pulp and paper industry. However, the technology is mainly used in the sulfate process and is seldom seen in the sulfite process.

The operational principle

In this particular type of evaporator, the leaching solution is conveyed from the bottom to the top through a shell-and-pipe heat exchanger. Heating occurs from the outside, usually with steam.

- As the leach absorbs heat, the change in density causes the vapor to move upward with the liquid.
- Once the mixture of liquid and steam reaches the top, the steam evaporates due to the high temperatures in the evaporation vessel, causing it to separate from the spent liquor.

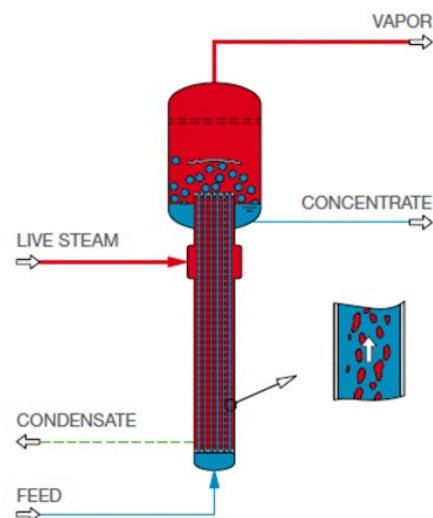

Low-energy consumption, but a narrow operating window

A significant advantage associated with this technology is the comparatively low electrical energy consumption, as no pumps are required. At the same time, however, in the event of difficulties encountered in the process, it is not possible to rectify the fault with the aid of the pumps. Rising film evaporators, therefore, have a very narrow operating window and are difficult to regulate.

Rapid fouling & clogging of the pipes

The rising film evaporator is prone to rapid scaling and clogging of the inner surface of the pipes. The deposits that form inside the heat exchanger are challenging to remove. Once the pipes are clogged, all the pipes or the entire apparatus must be replaced. Failure to do so will result in the loss of the heating surface for evaporation and a reduction in evaporation performance. This is also one of the main reasons modern processes in the sulfite industry have replaced this technology.

2. Forced circulation evaporator

An advanced version of the rising film evaporator is the forced circulation evaporator with a separate heat exchanger. Although these evaporator types are still in use in the cellulose industry for the sulfite process, they are rarely built nowadays because of the significantly improved efficiency of evaporator technologies.

The operating principle

Forced circulation evaporators are better suited for concentrator stage applications than rising film evaporators because they can deal with high viscosities more effectively

- Um A circulating pump is used to move the spent liquor through the heat exchanger, which increases the operating window.
- Die The solution flows along the heated surface, usually a pipe bundle, and begins to boil. In the evaporation vessel, the liquid decompresses, and the vapor separates from the leach.
- The liquid is then returned to the heat exchanger, and the process cycle begins again.

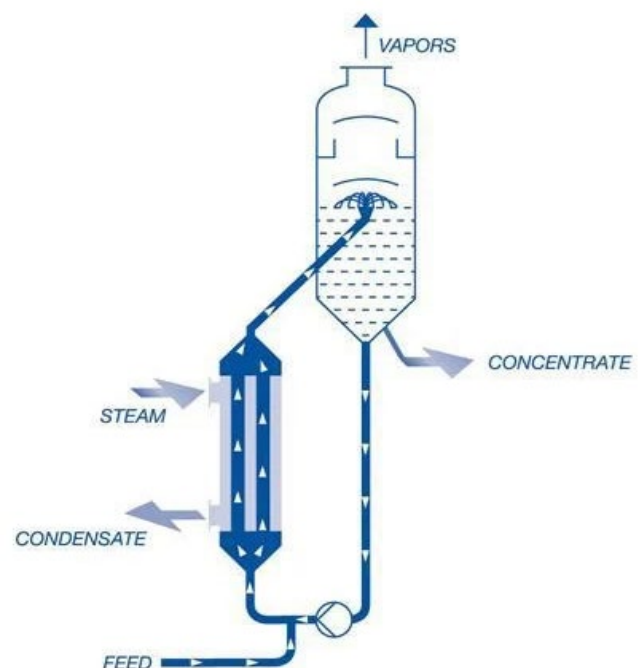

High operating costs due to low heat transfer

A significant disadvantage associated with this technology is the comparatively low heat transfer, which requires very high circulation rates to achieve the desired evaporator performance.

As a result, the circulating pump consumes a considerable amount of energy, leading to significantly higher operating costs than the rising film evaporator.

Fouling and corrosion limit working life

This technology has not been able to solve the fouling and corrosion problem either. Cleaning the heat exchanger requires taking the plant out of operation and removing the heat exchanger.

Depending on the type of heat exchanger, removal or cleaning may be more or less time-consuming and thus cause operational standstills. In principle, chemical cleaning is possible, but the sulfite process always leads to heavy soiling and, consequently, corrosion...

Therefore, the working life of the forced circulation evaporator is limited. In most cases, the heat exchanger needs to be replaced altogether after an operating period of five to ten years. At costs of several 100,000 euros and a comparatively short operating time, this is a cost-intensive undertaking.

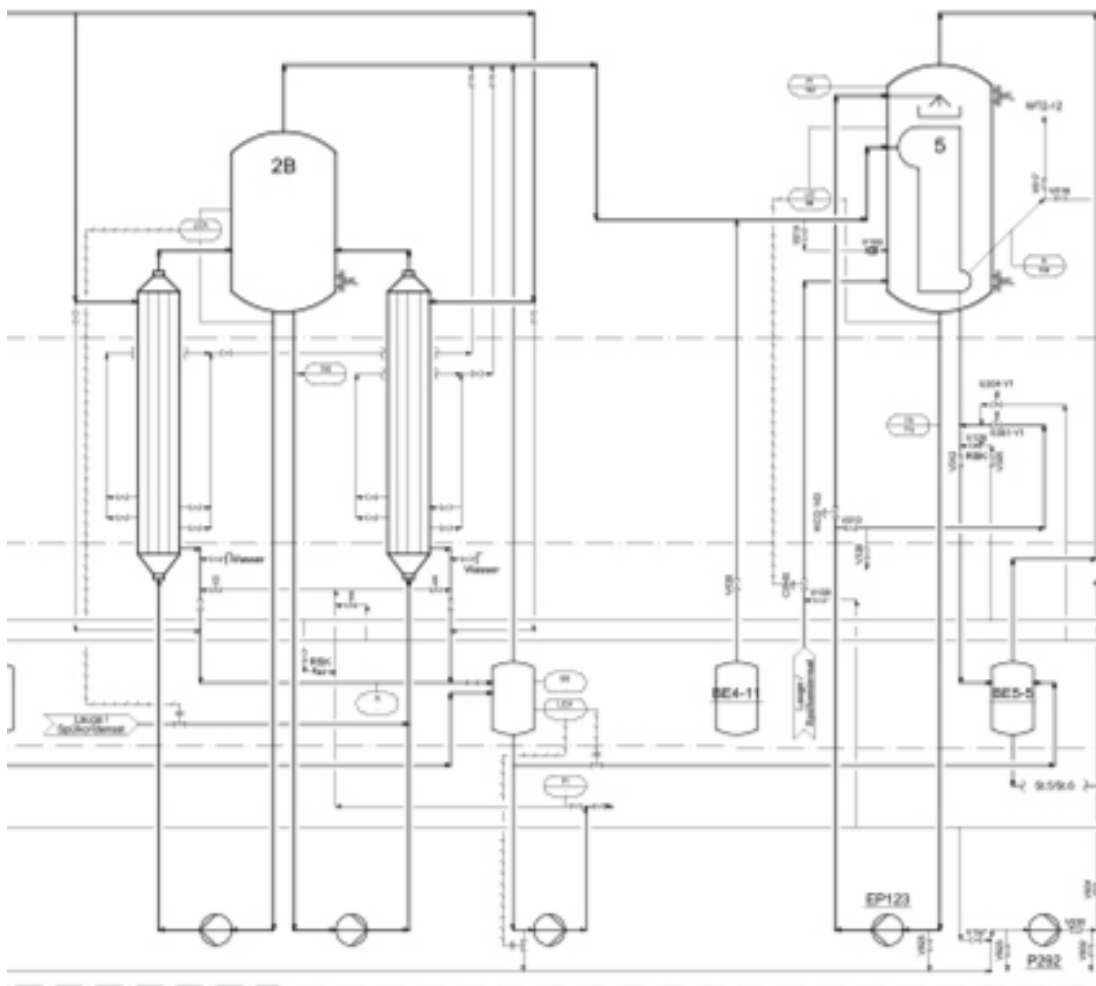

Comparison of forced circulation evaporator with 2 heat exchangers vs. plate falling film evaporator

3. Tube falling film evaporator

The next stage in the development of evaporator technology are [tube falling film evaporators](#). These evaporator types are used primarily for low-fouling media and smaller-scale applications.

For example, tube falling film evaporators can be optimally utilized in the sulfate process at low concentrations in the pulp industry. However, this technology is less suitable for the sulfite and sulfate processes at high concentrations (due to the cleaning difficulties).

The operating principle

In contrast to the two previous technologies, the leach is no longer fed into the tube falling film evaporator from below but from above.

→ The distribution cup in the upper apparatus hood ensures that all tubes are uniformly pressurized.

→ Due to the force of gravity, the leaching solution flows downward through the tubes which are heated from the outside. The more volatile fraction evaporates at the heating surface and is conveyed below along with the concentrate in a co-current flow.

→ Subsequently, the vaporous phase (vapors) is separated from the liquid phase (concentrate).

→ Any drops of spent liquor entrained in the vapor are separated from using a droplet separator, of which there are different types.

→ The vapor is constantly extracted as the concentrate at the bottom of the evaporator body is fed into the next evaporator stage or process step by a circulation pump.

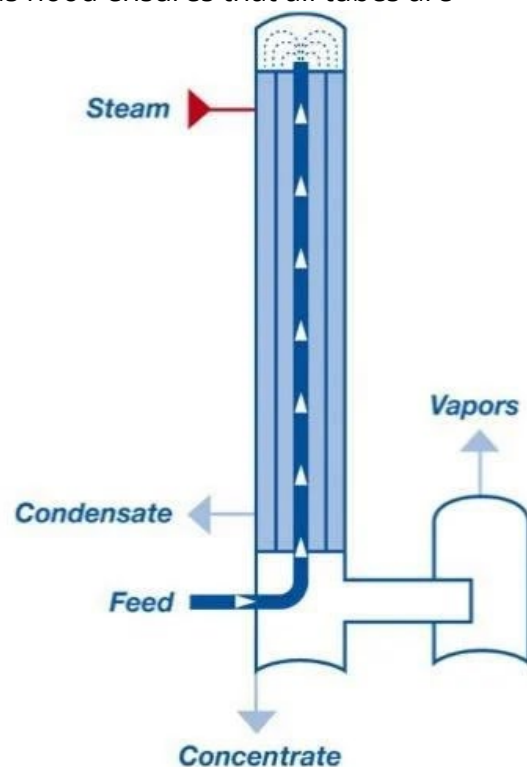

Lower energy demand with a high operating window

Compared to the forced circulation evaporator, significantly lower circulation rates are required due to surface evaporation directly at the heating surface. On the one hand, there is a shorter product residence time and, on the other hand, significantly lower energy consumption. At the same time, the use of pumps makes the apparatus more controllable and facilitates a larger operating window.

Fouling & clogging of the pipes continues to be a problem

Particularly in connection with sulfite liquors, the incrustations build up very quickly in the pipes, starting from the bottom, since the concentrations are greater in this area. Clogging can occur within hours or days, depending on the temperature and concentration. As soon as blockages occur, there is a risk that the pipe will completely close up all the way to the top. Cleaning is then no longer possible. The heating surface becomes inactive, and the evaporator capacity in the affected pipe is lost.



Corrosion makes the heat exchanger inoperable

Also problematic are corrosions, which occur increasingly underneath the fouling deposits. Corrosion of the pipes up to the pitting makes the heat exchanger sooner or later inoperable. Either the evaporator can be re-piped, or the entire unit replaced. Both options are costly.

Re-piping means a shutdown lasting several weeks, which involves expenses amounting to several 100,000 euros per day in the pulp industry. The purchase of a new apparatus quickly reaches a higher 6-digit range and is therefore very expensive.

4. Spray falling film evaporator

The spray falling film evaporator originated from seawater desalination and was sometimes used in the sulfite process.

Unlike the above-mentioned evaporator types, the leachate is not fed through pipes, but is sprayed onto the heated pipes on the outside of the shell.

There were hopes that this would improve the cleanability of the heat exchanger. However, the technology failed to find approval because the same fouling and corrosion problems occurred as before like the other evaporator types.

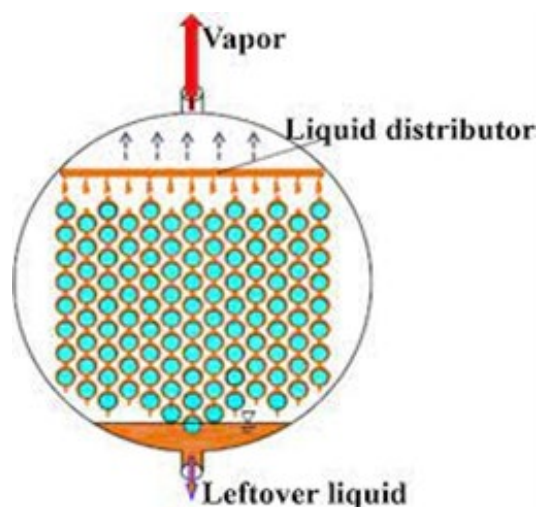

5. State-of-the-Art: Plate falling film evaporator

The latest development and, at the same time, state-of-the-art technology in the sulfite sector is the [plate falling film evaporator](#). However, it works the same way as the tube falling film evaporator, with the significant difference that the plate bundle is heated from the inside instead of a pipe bundle heated from the outside.

The operating principle

The sulfite liquor is pumped into a distribution cup at the top like the tube falling film evaporator. The leaching solution then flows down along the outside of the heating plates and evaporates. Due to the large distances between the plates and the cylindrical shell of the evaporator, the vapor produced has ample room to spread.

- The evaporated vapor flows slowly sideways into the evaporator body, leaves the evaporator via the droplet separator, and can be used again for heating the heating elements.
- The unevaporated portion of the liquor, the concentrate, is removed at the lower end of the evaporator body.
- A part of the concentrate stream leaves the evaporator as a product and is fed into the next process step.
- The condensed vapor (condensate) leaves the evaporator via a condensate collector at the lower end of the plate bundle.

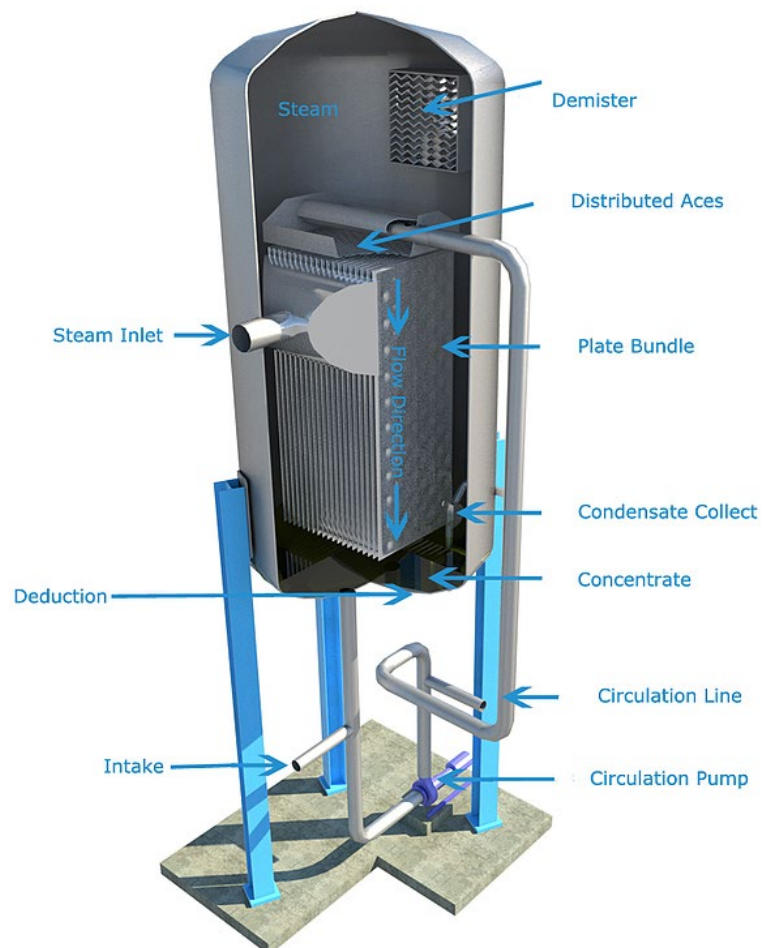

High efficiency with low energy consumption

Since the plate falling film evaporator offers a large volume and the leaching solution is fed in countercurrent to the vapor, a relatively slow vapor flow is produced compared to the tube falling film evaporator (co-current).

In this way, excellent separation of the liquid and vapor phases occurs, so plate falling film evaporators work very efficiently and are state of the art. As a result, evaporation capacities up to 700t/h or more are possible.

Furthermore, the slow flow rates also result in a low-pressure drop and low energy consumption. Therefore, only low circulating pump capacities are required.

Minimal fouling due to optimized plate bundles

- The core element of the plate falling film evaporator is resistance spot welded heating elements in different formats which are manufactured by using induction. Keeping the caustic solution on the outside of the heating surface or mechanical and chemical cleaning methods decreases the risk of fouling and corrosion, thus ensuring very long operating times. The advantages of the plate bundles can be summarized as follows:
- Minimal risk of fouling owing to very smooth sheet surfaces and a self-cleaning effect due to shrinkage of the lamellae during cleaning.
- Low risk of corrosion on the surface, as the basic structure on the welding spot surface remains unchanged because of resistance spot welding.
- No deformation due to cold and tension in the weld-affected zone thanks to ingenious fixtures
- Minimized risk of tension corrosion cracking.
- The welded edge ensures maximum utilization of the heating surface, no gaps, and loadable weld seams as plate endings. The service life of the lamellae can thus be significantly increased.
- Worldwide transport & installation is possible through the optimal design of plate bundles for standard containers.

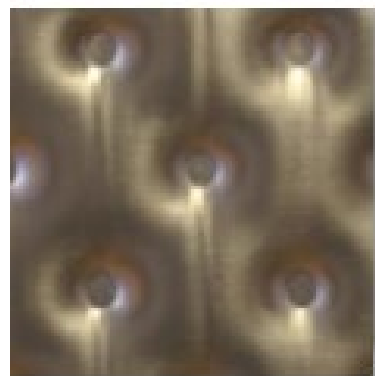

Self-cleaning effect of the plates

The boards have the characteristic that, by using different operating and cleaning temperatures and the resulting different thermal expansion, gypsum coatings are chipped off.

Due to this self-cleaning effect, little to no incrustations arise. Therefore, an effective cleaning process does not occur with the tube falling film evaporator.



Optimal cleanability thanks to accessibility of the evaporator

The main advantage of the plate falling film evaporator is that the leaching solution is located on the shell side. Compared to the tube falling film evaporator, it is much easier to clean.

Accessibility of the evaporator and ample space between the plates enable uncomplicated removal of fouling, both chemically and mechanically.

Integrated and cleanable droplet separator

This technology enables the droplet separator to be installed into the evaporator. A separate apparatus is no longer required for the plate falling film evaporator since the low vapor velocity limits droplet entrainment.

The droplet separator is also very easy to clean so that the vapor remains clean and the condensate has high quality.

Uncomplicated exchange of the plate bundles

In the sulfite process, severe fouling is possible, so that in extreme cases the heating surfaces are impossible to clean. In such cases, an uncomplicated exchange of the bundle is possible.

First, the evaporator body is opened at the top, then the bundle is lifted out, and a new one is installed. The replacement of the bundle is completed within the time frame of a normal operational shutdown.



Conclusion: Evaporator types in the pulp industry

Rising film and forced circulation evaporators are hardly ever used in the sulfite industry because of significantly higher operating costs and poorer evaporation rates.

Spray falling film, and tube falling film evaporators are also not optimally suited for use in the sulfite process, as they cannot satisfactorily solve the problem of fouling.

Today, state-of-the-art is the plate falling film evaporator, whose technology offers significant technical advantages and ensures easy cleanability and thus a long service life for the apparatus.

Cleaning of evaporation plants: The following must be taken into account in the sulfite process

When operating evaporation plants using the sulfite process, deposits of substances accumulate on both sides of the heat exchanger, which permanently disrupt the operation of the plant. Therefore, cleaning the evaporator plays a decisive role in achieving a reliable process and ensuring the long-term operability of the evaporation plant.

Gypsum and furfural deposits in the sulfite process

In the sulfite process, the fouling of the heat exchanger is an important issue. Even thin layers of less than 0.5 millimeters can significantly reduce heat transfer and, therefore, the evaporator performance.

Most of the deposits on the heat exchanger surface of the medium requiring evaporation, are gypsum deposits. Deposits of furfural develop on the surface of the heating medium (vapor) because of the chemical nature of the medium.

To reduce the adverse effects of these deposits, it is necessary to clean evaporation plants regularly at high operational costs. Cleaning is carried out differently for both the medium and the heating steam side.

Cleaning the medium side (gypsum))

Gypsum deposits that form on the caustic side of the heat exchanger can develop into incrustations due to residual fibers in the caustic, which stick to the heat exchanger as if they were burnt together. Regular rinsing is part of the operating program, and mechanical cleaning during the annual shutdowns.

1. Regular washing cycles

Regular washing cycles with vapor condensate or thin liquor ensure efficient operation and uniform evaporation. In addition, the solubility of gypsum in self-condensate/thin liquor is utilized to remove the gypsum deposits.

Most evaporators have a Cleaning-in-Place (CIP) system installed to control the wash cycles. The interval between rinses depends on the concentration in the respective

evaporation stage. Highly concentrated evaporation stages are usually switched from caustic operation to rinsing operation every eight hours, while one to two rinses per month is sufficient for lower concentration stages.

Note: In principle, rinsing chemicals can also clean the leach side, but only during a shutdown. Conventional methods include cleaning with self-condensate or thin caustic solution during operation.

2. Mechanical cleaning at standstill

After an extended operation period, despite regular flushing, a deposit builds up on the evaporator surface, which must be removed from time to time. Therefore, the heat exchanger is mechanically cleaned using high-pressure spray lances, tank cleaning equipment, or special heat exchanger cleaning tools during routine shutdowns. Cleaning usually takes several days and can be carried out within the time frame of a normal shutdown.

Cleaning the heating steam side (Furfural)

The heating steam side is cleaned chemically with nitric acid or hydrogen peroxide during the shutdown. In addition to the standard safety measures, it is essential to wear protective clothing when cleaning with nitric acid. Furthermore, it is necessary to ensure that the reaction gases produced are discharged to prevent an impermissible increase in pressure in the plant:

- Cleaning with nitric acid produces toxic nitrous gases, which must be thermally disposed of via a boiler.
- .The reaction gases with hydrogen peroxide are unproblematic and may be released into the atmosphere.

Essentially, chemical cleaning of the heating steam side can be carried out during operation. However, this requires very complex precautions, as the chemicals must never directly contact the caustic solution, given their high level of reactivity. In such cases, each stage needs to be separated with blind or block circuits to prevent faulty switching.

Comparison of cleaning properties of tube and plate falling film evaporators

In the sulfite process, tube and plate falling film evaporators are primarily used. As far as cleanability is concerned, there are considerable differences, which we would like to discuss in brief.

1. Cleaning plate falling film evaporator

The main advantage of the plate film evaporator is the leach located on the outside of the heat exchanger.

In addition, the walk-through nature of the evaporator and the large spaces between the plates mean that the soiled surfaces are easily accessible and can be efficiently cleaned both mechanically and chemically.

The plates also have a self-cleaning effect that continuously reduces plaster deposits even during operation. As soon as the evaporator is activated to flush, there is a change in the heating surface temperature, which causes the plaster deposits to flake off. Due to this self-cleaning effect, only a little or no incrustation occurs.

In addition, the droplet separator integrated into the evaporator can also be cleaned easily, ensuring high condensate quality.

2. Cleaning tube falling film evaporator

As soon as incrustations form in the pipes, they can no longer be rinsed away.

In addition, mechanical cleaning of these incrustations is problematic because tube falling film evaporator can only be accessed from above.

Optimal cleaning throughout the entire heating surface is time-consuming since several hundred pipes often have to be cleaned mechanically one at a time.



Reduction of deposits through the proper design

With the appropriate layout of falling film evaporators, fouling caused by sulfite liquors cannot be prevented but can be minimized. Three factors, in particular, play a significant role in this respect:

- 1. Temperature:** Fouling on the leaching side can be reduced by limiting the temperature in the highly concentrated stages to about 125 degrees Celsius. The reason is that deposits and incrustations massively increase at higher temperatures.
- 2. Impact:** Fouling on the caustic side can be minimized by selecting the proper circulation rates (= effective wetting).
- 3. Heating surfaces:** An additional consideration is to design the heating surface so that its load is not too high and not too much is evaporated per square meter of heating surface. Accordingly, larger heating surfaces are beneficial for reducing deposits with minor temperature differences. However, investment costs and operating costs have to be taken into consideration.

Ultimately, deposits cannot be wholly prevented in caustic sulfite solutions. Still, there are ways of minimizing fouling by observing the temperature, the impact, and the size of the heating surface.

Conclusion: Cleaning evaporation plants in the sulfite process

Deposits in evaporation plants used in the sulfite pulp industry must be regularly cleaned to maintain the evaporation capacity. Plate falling film evaporators are designed to meet these requirements as the plates have a self-cleaning effect that facilitates vapor condensate cleaning.

In addition, the accessibility of the plate falling film evaporator significantly improves the opportunities for mechanical cleaning compared to the tube falling film evaporator.

However, regardless of the type of evaporator, it is ultimately important that the evaporators are regularly and thoroughly cleaned mechanically or chemically, with vapor condensate at least once a year during a shutdown. Permanent deposits are very costly and result in reduced plant efficiency.

Innovative use of side streams

The extraction of valued products from side streams is becoming increasingly important from an ecological and economic point of view. As a result, efforts are increasingly being made to recycle these by-product streams and use them economically. Some lucrative by-products from the sulfite process are featured in this article.

The sulfite process in the paper and pulp industry

According to history, the sulfite process is the oldest method of obtaining pulp from wood. This method is known as "acid pulping" because the sulfite pulp is produced at a pH value between 1.5 and 5. Calcium, ammonium, magnesium, or sodium are used as bases.

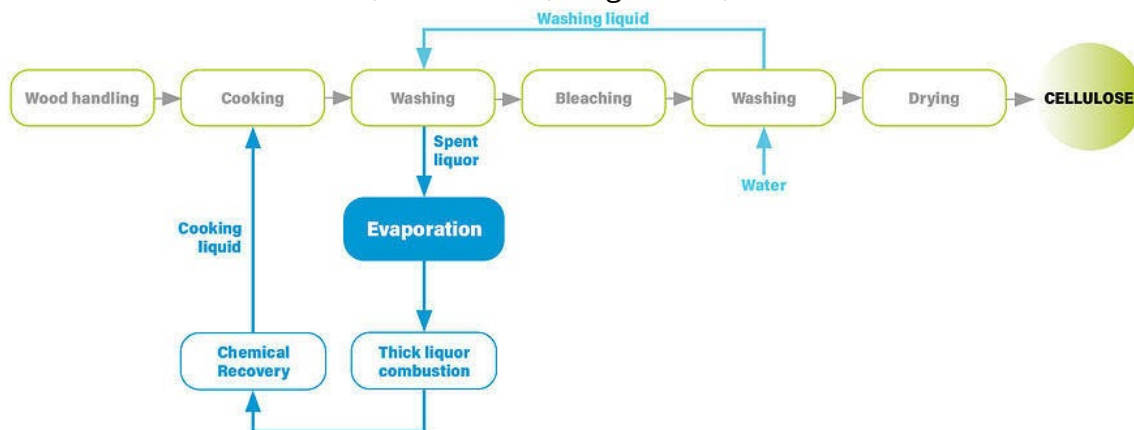

In a chemical pulping and cooking process, the pulp fibers are detached and exposed from the hemicelluloses and lignin's "putty substance" of the wood. The fiber pulp is then separated from undigested wood particles and washed in the caustic collection system. In this process, the fibers are separated from lignin and resins and further processed separately:

1. **Fiber line:** The cellulose and hemicellulose fibers are cleaned, bleached, dewatered, and dried in different processes.
2. **Liquor line:** The liquor (containing lignin and resins) produced as a side stream during the washing process is too low in viscosity for direct combustion and must be evaporated. The sulfite liquor, therefore, usually enters the evaporation plant as feed, where it is concentrated and only then fed to the liquor boiler (recovery boiler) as fuel.

The energy released during combustion is used to generate steam energy and electricity. As green energy, it can be used directly in the pulp mill or fed into the local district heating network or public power grid. Parallel to combustion, the pulping chemicals are reclaimed for reuse in the cooking process. This completes the sustainable cycle.

Added value through the use of by-products

Only one-third to two-thirds of the starting product is used in pulp production for the main product, cellulose. However, the remainder of the raw materials used accumulates as by-products dissolved in the sulfite liquor.

Depending on the pulping process, a combination of calcium, magnesium, sodium, or ammonium waste liquor with hemicelluloses, sugars, sugar acids, organic acids, and inorganic salts is obtained.

This by-product stream is a chemical raw material source containing many valuable organic substances and at least 50 percent of the original wood substance.

As the recycling economy continues to develop, there are numerous opportunities to convert the biogenic constituents of the sulfite liquor into valuable products before the liquor undergoes thermal recycling.

Increased diversification in sulfite pulp mills

Currently, research is ongoing in the pulp industry on developing processes that use new pulping chemicals and raw materials. As a result, other valuable materials will be produced and offered on the market as end or intermediate products.

Sulfite plants, in particular, are attempting to diversify with alternative feedstocks, chemicals, or products from waste streams. In this case, new or alternative process equipment may be required (different raw material properties, different parameters, different by-products, different materials required)

GIG Karasek has in-depth experience and process know-how in various applications and industries and can test and scale new approaches for process solutions to recover by-products with its pilot plants in the in-house technical center.

Intensive test series with sample material from customers provide the basis for assessing whether or not a valuable product can be generated from the by-product stream. It is also possible to test new raw materials and chemicals on a pilot scale. In the process, the necessary data for scale-up are determined.

The biorefinery concept is becoming increasingly important

In addition to extracting individual products from side streams, bio-refineries offer great opportunities for climate protection, value creation, and resource efficiency in the context of the bioeconomy.

The biorefinery processes focused on recycling biogenic raw materials and residues with as little waste as possible to obtain intermediate and end products that can replace products made from fossil raw materials.

Biorefineries may be classified according to four main characteristics ([IEA Bioenergy Classification System](#)):

1. **Feedstock** (basic materials)
2. **Processes** (transformation processes: chemical, thermodynamic, mechanical-physical)
3. **Platforms** (important intermediate products)
4. **Products** (substance- or energy-related)

The most promising model among the large-scale industrial bio-refineries is the lignocellulose bio-refinery model with diverse characteristics.



Valuable by-products from the sulfite process

As a niche segment, sulfite pulp processes are a lucrative business with many additional possible by-products. Considering that the evaporation plant is the preliminary stage for the thermal utilization of the sulfite liquor, many side streams from the evaporation plant and its surroundings are used.

Additional by-products can be acquired from secondary sources, such as washing and bleaching processes (e.g., soda, ash) or downstream plants of the regenerated fiber industry (e.g., co-products, solvent recovery via evaporation plant).

1. Acetic acid

After separating the raw pulp, the sulfite liquor is evaporated. Acetic acid accumulates in the vapor condensate, in very acidic processes using special types of wood (e.g., beech, birch, etc.)

Since the acid causes considerable problems in the evaporation plant, it is typically removed by thin liquor neutralization located upstream of the evaporation plant.

However, it is also possible to convert the acetic acid produced into a high-value product and, at the same time, eliminate the problems in the process.

The [Lenzing Group](#) is a company that has been using acetic acid as a raw material for several decades. The acetic acid accumulates during pulp production from beech wood and is refined into high-quality acetic acid in several steps.

Acetic acid applications:

Acetic acid is one of the most important basic chemicals and has a vast range of applications in various downstream industries and numerous industrial chemical processes.

It is well established in the food, textile, chemical, pharmaceutical, and cosmetic industries.

The chemical is an excellent solvent and is often used as a reactant.



3. Xylose (Wood sugar)

Waste liquor from hardwood sulfite pulping has a xylose content of 10 to 20 percent, based on the dry substance content. In a unique process, the wood sugar is extracted from the concentrated liquor, and the xylose solution is subsequently concentrated in an evaporation plant. GIG Karasek, for example, is currently building a Turn-key Skid Plant with a [thin film evaporator](#) that further concentrates the xylose in a Scandinavian plant.

One of the world's leading producers of xylose is [DuPont](#). The company operates a xylose production plant in Austria, a facility that is integrated in Lenzing's pulp mill. The xylose is extracted from the sulfite liquor and processed into xylitol.

Once the xylose is separated, the remaining side stream with reduced xylose content and energy value, returns to the pulp mill for evaporation or combustion and energy production.

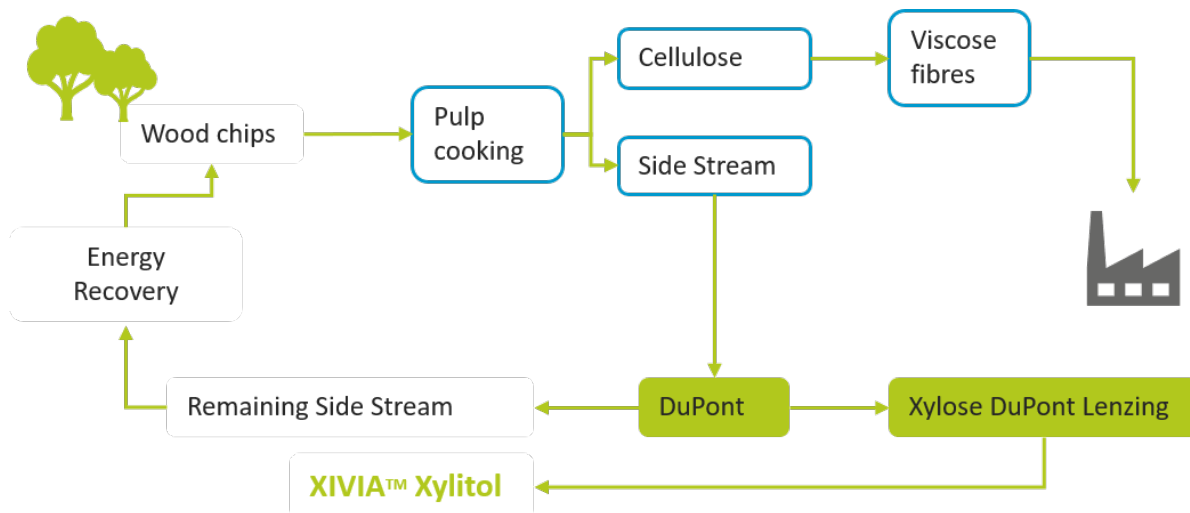

Xylose applications:

Xylose is a valuable raw material in the candy, aroma, and flavor industries and, in particular, a raw material in the production of xylitol. In the cosmetic industry, xylose is used as an additive to keep cosmetic preparations moist. Another application is in veterinary medicine as a xylose absorption test to diagnose malabsorption. A relatively new application is hydrogen extraction from xylose, with high yields by a cell-free enzyme cascade. In addition, xylose can be chemically converted to furfural.

4. Bioethanol

An additional product that can be obtained from xylose, apart from xylitol, is bioethanol. Conversion of xylose to bioethanol is achieved by fermentation of the sulfite liquor and subsequent distillation. Any remaining stream from the recovery process can be recycled back to the evaporation plant.

The world's largest wood-based bioethanol plant was launched by the Hallein-based pulp mill [AustroCel](#) in early 2021. In its biorefinery, AustroCel attempts to utilize all components of the wood.

Wood sugar is used to produce second-generation bioethanol, which can be added to gasoline fuels as an "advanced biofuel" thanks to its sustainable nature. AustroCel's production replaces around 1 percent of annual gasoline consumption in Austria.

Bioethanol applications:

Apart from its use as a biofuel, bioethanol can be used wherever synthetic ethanol from petroleum production is used. In addition, bioethanol acts as an essential solvent and intermediate in the chemical-technical industry, a carrier for odorants, an additive for cleaning agents or antifreeze agents, and as fuel (alcohol).



© AustroCel Hallein / Michael Schartner

5. Lignosulfonate

Lignosulfonates are lignin compounds obtained through a unique purification process from the sulfite liquor. In addition, thermally driven separation processes such as evaporation can also be used.

The Norwegian company [Borregaard LignoTech](#) is the world's leading manufacturer of lignin- and lignosulfonate-based products. The company has been supplying the chemical industry with binding and dispersing agents for over 60 years.

Applications Lignosulfonate:

Lignosulfonates are highly versatile and widely used in various industrial applications.

They serve as binders, dispersants, emulsifiers, and sequestering agents in multiple products such as concrete, cardboard, plasterboard, chipboard, fireproof boards, animal food, fertilizer pellets, dyes, and detergents.

In addition to these key applications, lignosulfonate serves as a raw material for chemical manufacturing.

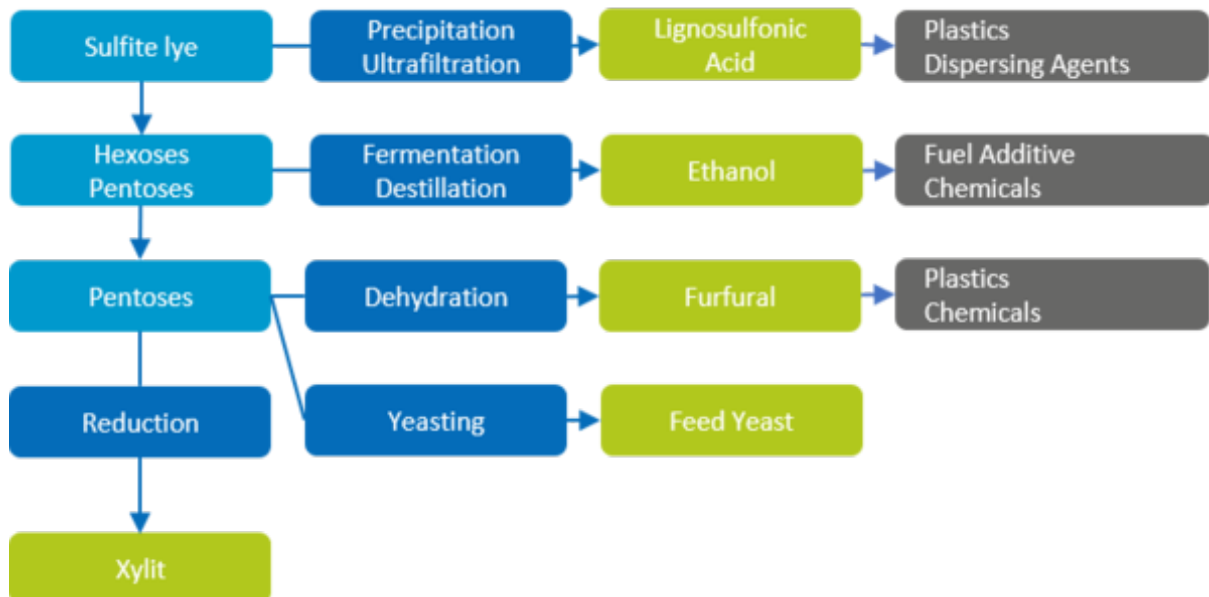

6. Soda

Soda is a valuable product produced in the secondary sector as a by-product of the bleaching process.

Applications Soda:

Soda is an important raw material in the chemical industry for manufacturing glass, bleaching agents, detergents, dyes, and tanning products.

7. Vanillin

Pure vanilla is the second most expensive spice next to saffron and is not available in the required quantities. An alternative source is vanillin production from lignin, which is found in the waste liquor. The lignin is broken down in a chemical process, producing vanillin as a product of a reaction. The world's largest producer of bio-based vanillin from wood is [Borregaard](#). The company has been producing plant-based vanillin from a sustainably grown red spruce since 1962.

Vanillin applications:

The range of applications for vanillin includes food and beverages, flavors and fragrances, personal care, cosmetics, and pharmaceuticals. In pharmaceuticals, vanillin is mainly used as a base product for medicinal substances, for example, in L-Dopa, a drug used to treat Parkinson's disease.

Conclusion: By-products from the sulfite process

Several valuable chemicals can be isolated from the biogenic residues in sulfite liquors as by-products, serving as raw materials for further processing in the chemical industry and in numerous other industries.

GIG Karasek offers different solutions, including testing and developing new processes to separate side streams and extract valuable products.

In most cases, these side streams accumulate in the recovery process located around the evaporation plant, where they are recovered through different separation processes. Therefore, it is possible to thoroughly test and scale up both new process solutions and sample materials from side streams in our pilot plants

Saving energy: MEE and MVR in comparison

Evaporation processes in the pulp industry using the sulfite process are often very energy-intensive, and the installed equipment is outdated. Given the spiraling energy costs, solutions are required to save energy at affordable prices.

There are three fundamental options for an energy-saving plant design. These include multiple effect evaporation plants (MEE), plants with mechanical vapor recompression (MVR) and combinations of these technologies. These concepts will be presented below and compared according to their energy-saving capabilities.

Multiple effect evaporation plants (MEE)

To reduce live steam consumption, evaporation plants are designed as cascades. Only the first evaporator stage is heated with energy-intensive live steam, while the subsequent steps use the outflowing vapor steam from the previous location to heat the heating surfaces. In multiple effect evaporation plants using the sulfite process, five to seven stages connected in series are usually used.



1.The operating principle

Saving energy is achieved by using the condensation heat of the steam several times.

- For heat transfer to take place through several stages, the boiling temperature of the sulfite liquor in the respective location must be lower than the condensation temperature of the vapors on the heating side of the respective stage.
- Consequently, the pressure can be reduced continuously from the second stage to the last stage, thus reducing the boiling point.
- As a result, there is a sufficient temperature drop in each evaporator stage for heat transfer from the vapors to the sulfite liquor.

Therefore, the heating steam requirement decreases in inverse proportion to the number of steps installed. To sum up, the amount of steam required is approximately equal to the total amount of water evaporated, divided by the number of stages.

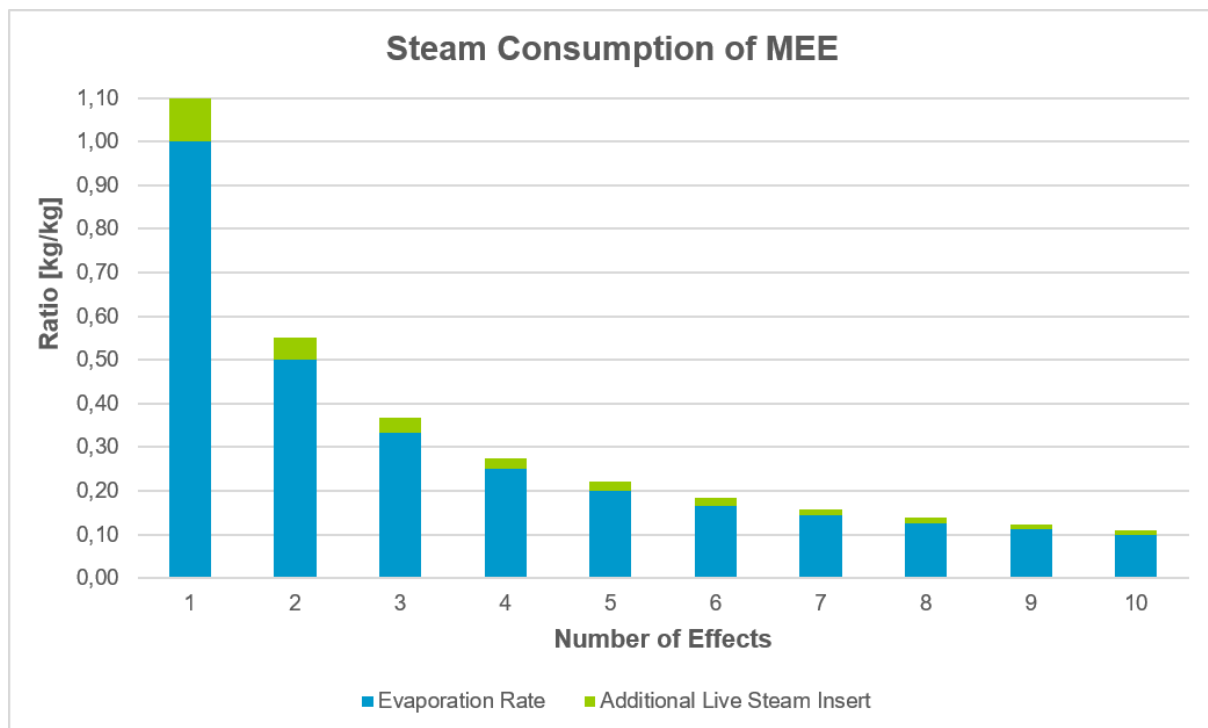

After the last stage, the vapor must be condensed and transferred to a coolant. For this purpose, large condenser surfaces are required, which must transfer approximately the same amount of energy previously supplied as heating steam. In addition, adequate cooling water at the lowest possible temperature is necessary to operate these condensers.

2. Temperature gradient limits number of stages

The total temperature difference that can be divided between the individual stages is determined by the highest permissible heating temperature of the 1st stage and the lowest boiling temperature of the last step.

The usable temperature difference on the heating surfaces is thus limited by the possible concentrate temperatures above and by an economic condensation level below.

The latter is about 200 mbar absolute pressure for the last stage and can generally only be achieved using an additional vacuum pump.

The addition of further stages is therefore only possible within the available temperature gradient, which is determined

- on the one hand by the temperature sensitivity of the medium (in this case sulfite liquor) and the maximum available heating steam pressure,
- and on the other hand by the cooling water temperature. .

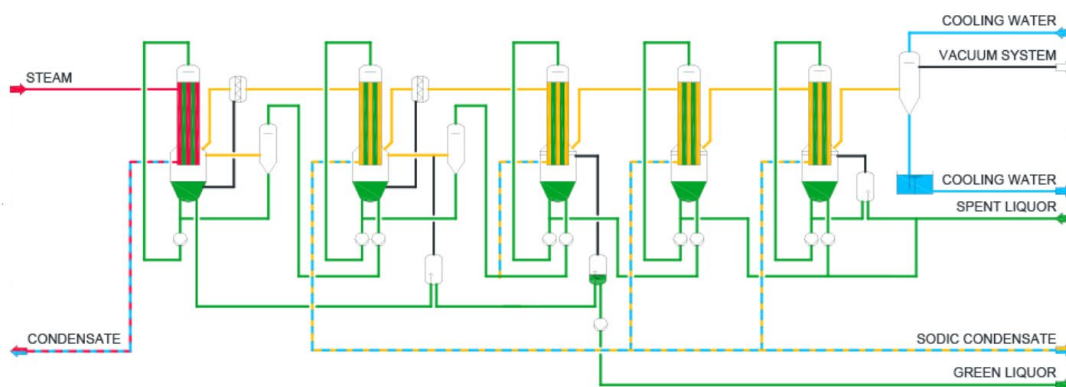

3. Investment costs increase with the number of stages

As the number of stages increases, the available temperature difference at the heating surface of each stage decreases. Therefore, the heating surface must be appropriately enlarged to achieve the desired evaporation performance, which means the investment costs increase as the number of stages rises.

At the same time, the energy saved is not as great.

The number of possible stages is limited

- on the one hand, physically limited by the maximum available temperature gradient
- and the cost-effectiveness of different heating surfaces.

The objective is to find the optimal balance between energy and investment costs. GIG Karasek determines this based on dedicated customer requirements or current operating data of the plant in close cooperation with the customer.

Therefore, the selected concept plays a central role in achieving the optimum economic design of a plant..



Evaporation plants with mechanical vapor recompression (MVR)

In addition to multi-stage plants, mechanical vapor recompressors (MVR) is used in the pulp industry to improve energy efficiency. Due to the drastic reduction of live steam, the technology is often used in combination with a single-stage or multi-stage plant.

1.The operating principle

Evaporation plants with mechanical vapor recompression are based on the open heat pump circuit principle, which means that the evaporation process is almost self-sustaining.

The vapors produced in the stage are brought to a higher pressure and temperature level by an electrically driven compressor to obtain higher-grade steam. This steam is then available again as heating steam and is usually used in the same stage to heat the evaporator heating surfaces.

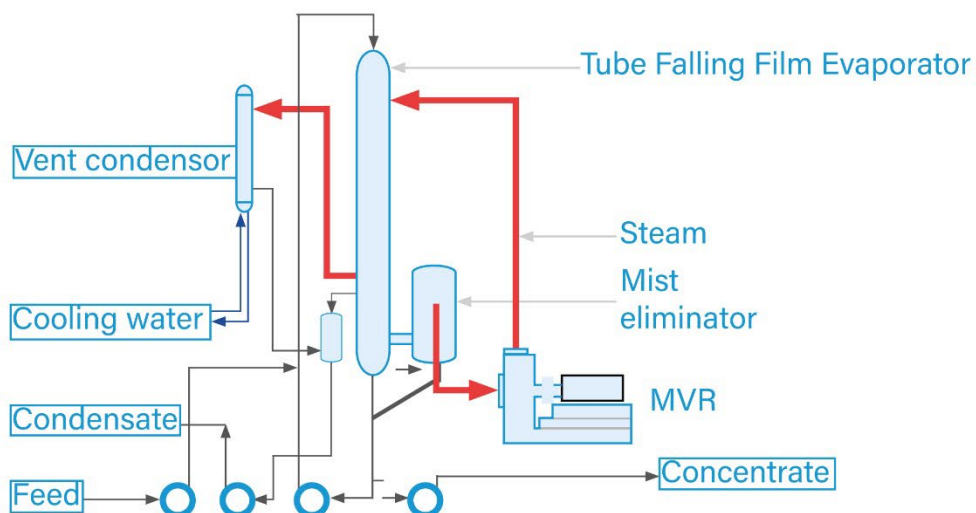

Therefore, mechanical vapor recompressors operate on the industrial heat pump principle, where multiple evaporation energy is achieved by introducing a fraction of mechanical energy..

2. Mechanical Vapor Recompression and increasing the boiling point

Most of the liquids to be evaporated have boiling point elevations due to the substances dissolved in them, which usually increase exponentially with the increasing concentration of the dissolved substances.

Therefore, the vapor produced in a stage does not have the temperature of the medium but only the evaporation or saturation temperature of the water or the evaporating medium.

Since the temperature increase achieved by mechanical vapor recompression with standard machines is between 7 and 9 °C, the boiling point increase must be accordingly low for this technology.

Therefore, the technology is particularly well suited for liquids with low solid concentrations or boiling point elevations, such as pulp liquors from sulfite processes.

Example:

Vapor recompression sulfite liquor with a boiling point increase of 5 °C

At the same boiling pressures, the boiling temperature of sulfite caustic is higher than that of its solvent water, depending on the concentration.

At lower concentrations, the boiling delay ranges between 1 and 1.5 °C; at higher concentrations, it rises to 4 to 5 °C.

- If, for example, sulfite liquor boils only at a liquid temperature of 105 °C instead of 100 °C, a boiling delay of 5 °C is present.
- The rising vapors then do not have an increased temperature of 105 °C, but only 100 °C.
- To reuse the steam that heats the evaporator, its temperature must be increased by a boiling delay of 5 °C plus the proper gradient required to maintain evaporation (according to experience, five °C).
- The steam must therefore be compressed to 110 °C.

3. Mechanical vapor recompression in the sulfite process

Due to the comparatively low boiling point elevation in sulfite waste liquors, it is possible to implement the entire evaporation process up to the final concentration with this technology.

As a result, it is possible to design evaporation processes that operate almost entirely without a live steam supply and cooling water. Instead, only electrical energy is required.

This technology is, therefore, particularly useful in locations with favorable electricity tariffs or little live steam/cooling water. The process is also highly relevant for the DACH-region, as many pulp producers still use the sulfite process

4. Design of mechanical vapor recompressor in the sulfite process

GIG Karasek uses centrifugal fans with peripheral speeds of up to 300 m/s and more in the pulp industry. As a result, moderate boiling point increases can be achieved using only one compressor. For more significant boiling point increases, two or three compressors are used in series, depending on the equilibrium conditions.

For example, in the sulfite process, one compressor is usually used for pre-concentration and two compressors in series for final concentration. However, since MVR plants cannot be enlarged arbitrarily, several vapor recompressors must be connected in parallel for processing high capacities.

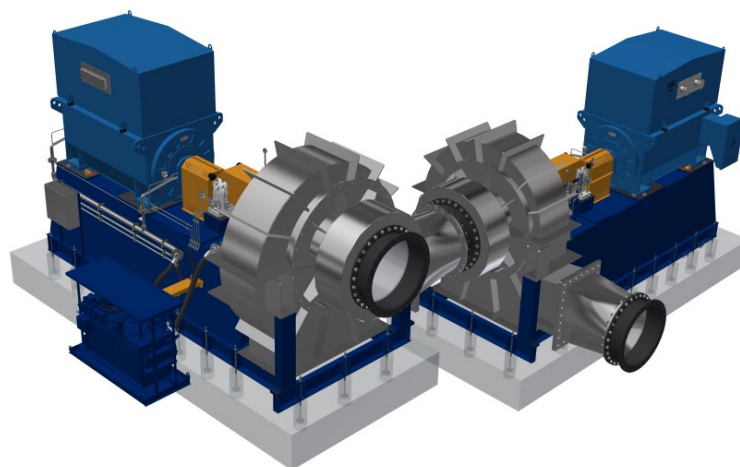

Upgrading existing multistage plants

In the past, it was primarily energy-intensive multi-stage evaporation plants that were installed, partly because of favorable energy prices. However, increasing live steam costs often make the operation unprofitable and drain profits.

Also, adding additional stages to reduce energy requirements or increase capacities is no longer possible or economical. There are various reasons for this, e.g.

- An additional stage is no longer possible due to the temperature gradient.
- The plant operator would have to use his cooling water exclusively if a parallel stage were installed (capacity increase).
- The cooling water must be treated before it can be used, resulting in considerable costs.
- There is too little steam available for an expansion of the multi-stage plant.

Plant operators who want to reduce their operating costs should therefore consider upgrading the system with electrically operated mechanical vapor recompressors. The investment costs for the conversion can rapidly pay off, especially if additional steam needs to be supplied.

Advantages of mechanical vapor recompression

Refitting a single-stage or multi-stage plant with a mechanical vapor recompression system does not require additional steam.

Only small amounts of live steam and cooling water are required.

Live steam is only used to start the plant and adjust the energy balance, which means that the mechanical vapor recompression runs almost exclusively on electrical energy.

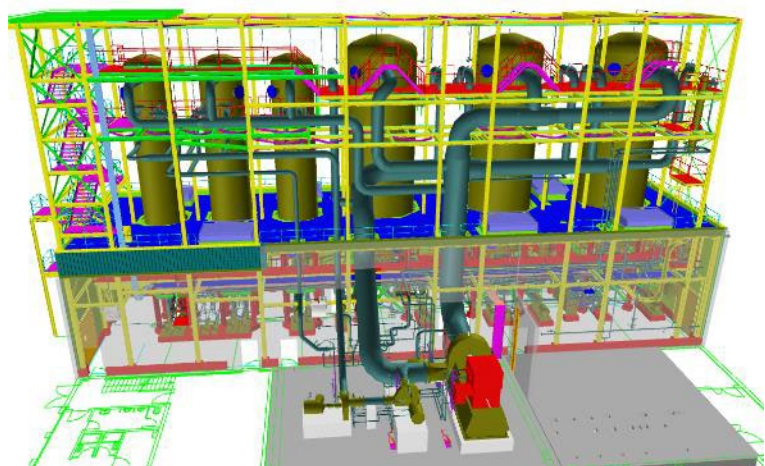

MRV plant versus multiple effect plant

So far, it was the investment costs that were significant. However, considering the global energy situation, energy costs are becoming increasingly crucial regarding the overall costs. Ultimately, the decision for each pulp mill has to be made individually, depending on the general conditions and the local situation. In brief, the most important advantages and disadvantages of the processes are summarized once again:

1. Prerequisites

- The successful application of MVR evaporation technology requires the liquid to be evaporated to a low-boiling delay, such as that of sulfite liquor.
- In addition, a stable power grid is needed, and the price of electricity must be lower than the price of steam if the application of MVR evaporation plants is economical compared to multiple effect plants.

2. Operating costs

- In direct comparison with single- or multiple effect evaporation plants, mechanical vapor recompression is a very energy-efficient process.
- This means that, for each ton of steam vapor, a comparatively minimal amount of electrical drive energy is required for the compressor motor.
- At the same time, there is no need for the cooling water that would otherwise be necessary, which means that additional operating costs can be reduced.

3. Investment costs

- In most cases, the investment costs of an evaporation plant with mechanical vapor recompression are higher than those of a comparable multiple effect plant.
- Depending on the evaluation of the steam in the overall plant, the lower consumption in operation can lead to a rapid ROI.
- When expanding multiple effect plants, eventual costs for a steam generator must be accounted for along with the investment for the additional stage.

Conclusion: Saving energy

To remain competitive, optimizing energy use is given top priority given the global energy situation.

Major reduction in energy costs can be accomplished using multiple effect plants and mechanical vapor recompression. Companies operating single- or multistage plants should consider upgrading their systems using vapor recompression.

GIG Karasek offers decades of expertise in implementing energy-saving measures in the pulp industry and provides the best available technologies (BAT) to fulfill the requirements of the industry as far as energy efficiency is concerned.



MBV-Anlage Sulfit-Zellstoffindustrie

Use Case: World's largest MVR-pulp mill Sappi Saiccor

GIG Karasek implemented the world's largest MVR evaporation plant in the sulfite pulp process for the Vulindlela project of the Sappi Saiccor pulp mill. The unique feature of this plant lies in the concentration of the sulfite liquor directly from the input concentration to the final desired concentration in large capacities.

The Vulindlela project

Sappi Saiccor is the world's largest pulp producer for the viscose fiber industry based on the sulfite process. The Saiccor mill is located 50 km south of the port of Durban in the South African province of KwaZulu-Natal and is one of the production establishments for Sappi Dissolving Pulp (DP).

An important objective of the Vulindlela project was to increase the plant capacity of the Saiccor mill from 783,000 tons to 890,000 tons per year. At the same time, production costs and the mill's environmental footprint were to be reduced by decreasing its reliance on fossil fuels.

In its entirety, the project included the installation of a new evaporator recovery boiler, a screening and washing plant, upgrades to the bleach plant and pulp machines, improved recovery circuits, and additional magnesium digesters.



Project management within a „Postage Stamp“ area“

GIG Karasek supplied the evaporation plant with mechanical vapor recompression for concentrating the sulfite waste liquor. Because of its high energy efficiency and low emissions, the innovative process solution positively affects the cycle and saves valuable resources.

For GIG Karasek, the Vulindlela project was the first and largest project on the African continent. The project started in May 2018 and was completed as scheduled in September 2021 despite Corona and all other difficulties.

The outstanding partnership with the client, the extensive remote work, and a strong construction site team, made this possible, despite the many challenges.

Project capacity and scope of delivery

The project volume was > 23 million euros. The evaporation plant was supplied on an EPC -basis (Engineering, Procurement, and Construction of the evaporator plant, including pumps, piping, valves, steel structure, insulation, HSE, and commissioning). The customer only provided the wiring and programming. The parts and components were procured globally and delivered from Europe, Asia, and South Africa.

230.000 accident-free working hours

The evaporation plant was built in the heart of the pulp mill, where an old plant had previously been demolished.

The available space on the heavily frequented construction site was relatively tight. To use Sappi's words: "The plant is being built on a postage stamp".

Despite these challenging conditions, the construction site team worked a total of 230,000 hours without any incidents..



MVR-evaporation plant: 300 t/h at 16 MW compressor capacity

The plant consists of the Tank Area (thick liquor, thin liquor, condensate tanks), four huge plate falling film evaporators, and the fan area with four mechanical vapor recompressors.

- With the enormous compressor capacity of 16,000,000 watts, 300 tons of water are evaporated, per hour, from the process in order to burn the sulfite liquor in the subsequent combustion boiler.
- The electrical power output is roughly equivalent to the output of the Graz Mur power station or 400,000 light bulbs (40W).
- For this purpose, two vapor recompressors were connected in series and two more were connected parallel.
- The evaporators each have a height of 14 meters, a diameter of over 6 meters, and a weight of 120 tons.
- The plant is distinguished by excellent cleaning properties, which guarantees durability..

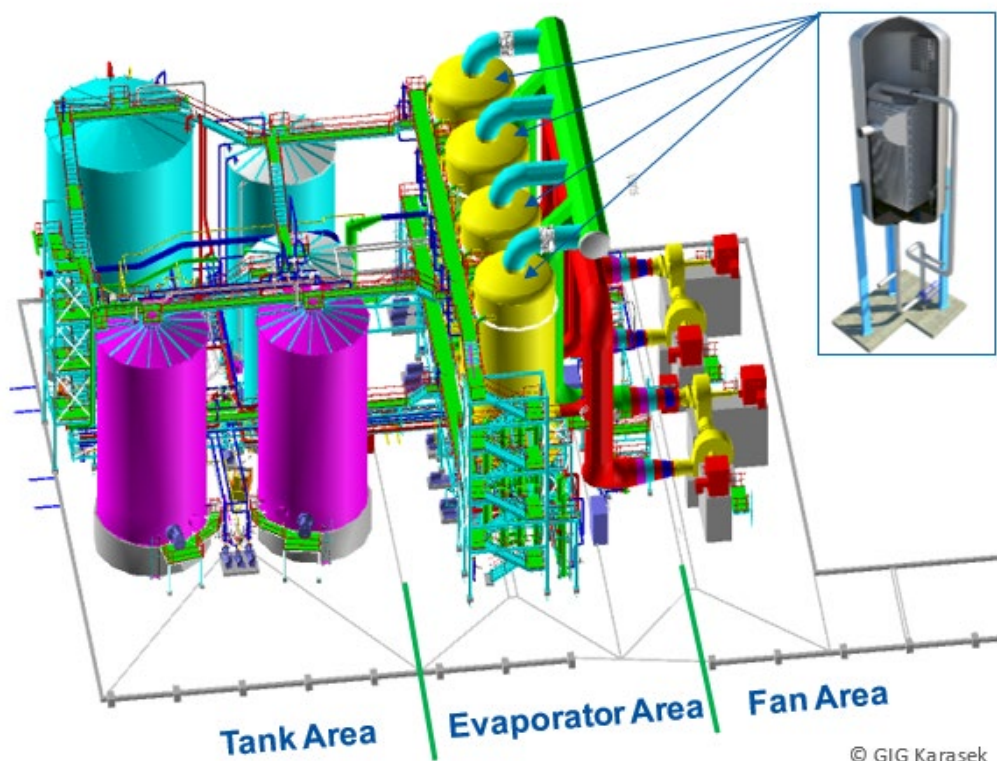

Tank Area

The individual tanks were prefabricated on the site with local suppliers and then mounted by crane on the previously installed foundation..



Evaporator Area

The individual tanks were prefabricated on the site with local suppliers and then mounted by crane on the previously installed foundation.



Fan Area

The process steam (vapor) is raised to a higher temperature level, consequently increasing to a higher energy level with the electrically driven mechanical vapor recompression system (radial fans) and then fed back into the process as fresh heating vapor.



Conclusion: Mechanical Vapor Recompression in the pulp industry

The combination of plate falling film evaporators and mechanical vapor recompression is an effective process solution for the concentration of sulfite liquors. With mechanical vapor recompression, the energy contained in the vapor is not lost but returned to the energy cycle. Consequently, high steam losses can be avoided. Plate falling film evaporators, on the other hand, are very easy to clean and provide a long service intervals. The implemented system thus operates in a very energy-efficient and environmentally friendly manner.

Key Figures - Project Vulindlela - Sappi Saiccor		
Contract type	-	EPC
Project volume	€	> 23.000.000
Working hours (accident free)	h	230.000
Project start	-	18.05.2018
Commissioning	-	Sep.21
Water evaporation	t/h	>300
Medium	-	Sulfite lye
Installed energy	MW	>16

Industrial waste heat utilization in sulfite pulp mills

The pulp industry is one of the most energy-intensive industrial sectors. A significant proportion of the energy used has been largely discarded as unused waste heat via exhaust air or wastewater. This heat can be used in an economically viable way to improve energy use and therefore reduce energy costs.

What to do with excess heat?

There are three options for the utilization of surplus thermal energy:

- 1. Internal-process waste heat utilization:** The waste heat is reintegrated into the same process (e.g. waste heat from the flue gas of a furnace is used to preheat the combustion air)
- 2. In-house waste heat utilization** The waste heat is fed to an in-plant consumer and reused in another process. It is also possible to use the waste heat to heat the plant buildings and heat water. Suppose waste heat is below the required energy level. It may be economical under certain conditions to use heat pumps to generate higher-temperature process heat from lower temperature waste heat.
- 3. External waste heat utilization:** The waste heat is extracted and fed into an external district heating or local heating network if there is no internal plant utilization option. At present, external heat utilization is still rarely implemented, but it will become increasingly important in the future.

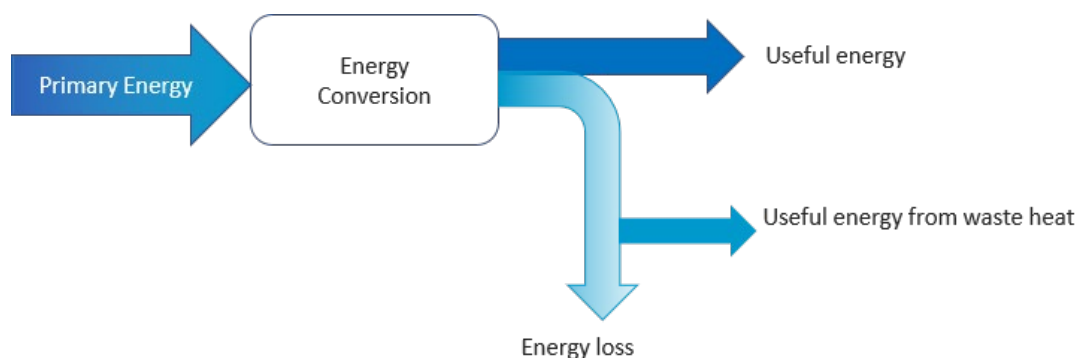

Efficient utilization of waste heat through cascade utilization

Excess heat at higher temperatures is frequently used in industrial processes in a cascaded manner. The waste heat passes through several phases connected in series with a decreasing temperature level to utilize the waste heat as efficiently as possible.

Example: Cascade utilization in a pulp mill

The waste heat is initially used to generate high-pressure steam or supplied to consumers that require high temperatures. Furthermore, this, in turn, creates waste heat but at a lower temperature level.

Such waste heat is available as additional waste heat potential, which can be used, for example, to heat products, as feed water, or as boiler water.

What remains is waste heat at low temperatures below 100 degrees celsius, for which there are often no internal consumers. Instead of disposing of this energy, the best option is to transfer it to a district or local heating network, which usually operates at specific temperatures of 70 to 100 degrees celsius.

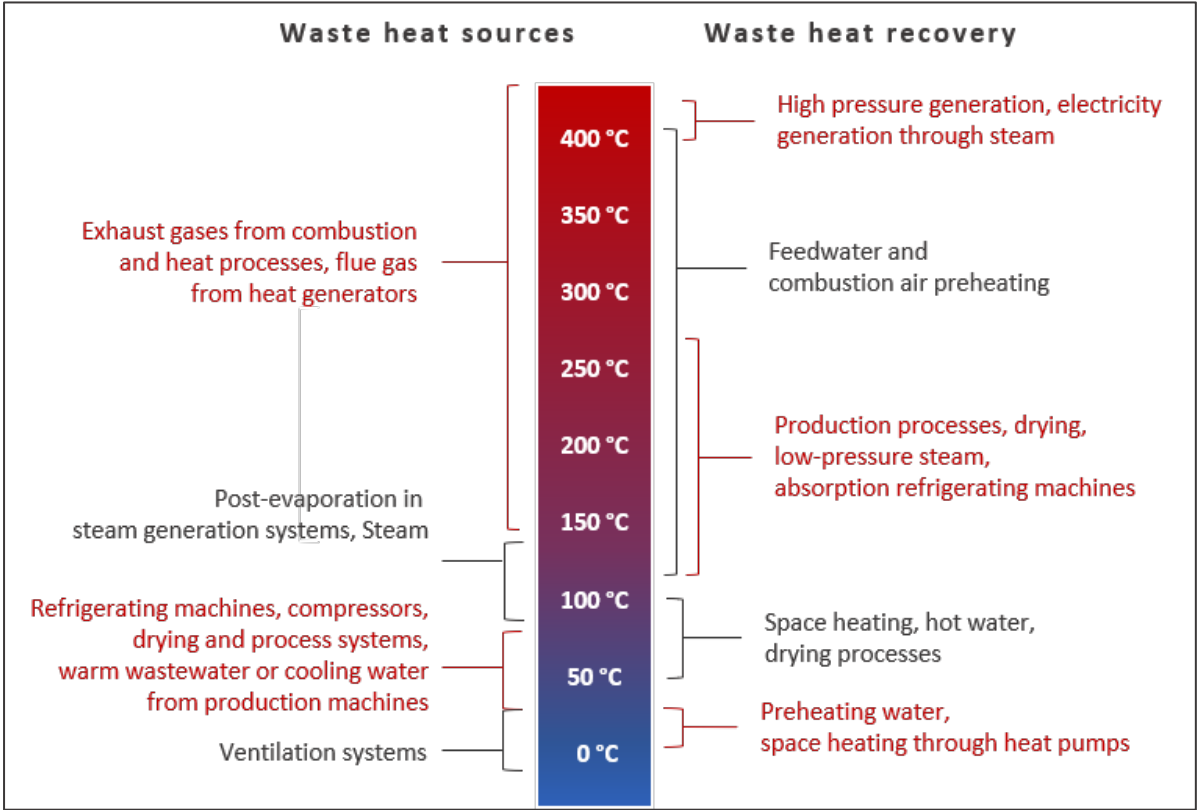

How are waste heat sources evaluated?

The production process in the pulp and paper industry involves numerous sequential production steps that take place at specific pressure and temperature conditions.

Consequently, excess heat energy is generated whenever lower temperatures are required in a process step than in the upstream process step. For efficient use of such waste heat, the potential of existing waste heat sources must be pinpointed and matched with existing waste heat reduction.

1. Identifying the potential of waste heat sources

The following parameters define the potential level of waste heat sources:

1. The **temperature level** of the waste heat source (the higher the temperature, the higher the value of the heat., the lower the temperature, the harder it is to find a customer).
2. **Heat quantity** or thermal power available in the waste heat medium (maximum and average power).
3. **Medium of waste heat** (specific heat capacity and composition).
4. **Time availability** (continuous or fluctuating, seasonal, number of full load hours per year).
5. **Safety and material requirements of the waste heat medium** (e.g. toxic or flammable substances, aggressive or corrosive components).

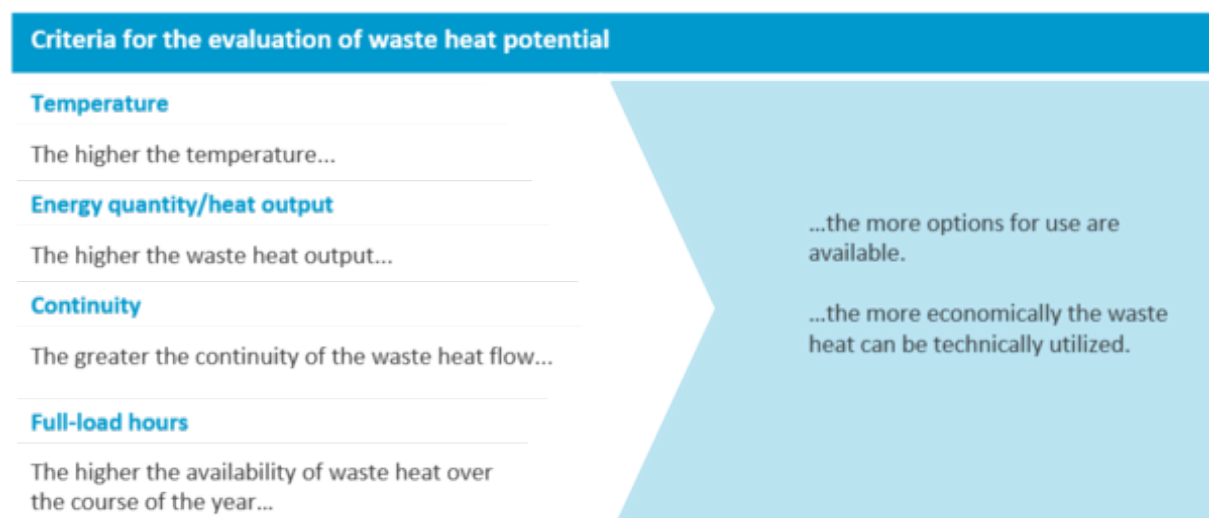

When assessing the potential for heat recovery in pulp mills two main prerequisites are important: firstly, sufficient residual heat must be available at the highest possible temperatures, and secondly, there must be consumers who can "utilize" the surplus heat.

2. Adjustment of waste heat source and waste heat reduction

The prerequisite for the economic implementation of heat recovery systems is the conformity of the waste heat source and the heat consumer. The most important criteria in this regard are: Voraussetzung zur wirtschaftlichen Umsetzung von Systemen zur Wärmerückgewinnung ist die Übereinstimmung von Abwärmequelle und Wärmeverbraucher. Die wichtigsten Kriterien diesbezüglich sind:

- 1. Temperatures of waste heat and heat requirements:** Since energy only ever flows from the warmer to the colder medium, the temperature of the waste heat should be higher than the temperature of the medium to be heated, as a general rule, the higher the temperature difference between the heat source and the heat sink, the more compact the design of the heat exchanger.
- 2. Heat quantity and heat output** Furthermore, the heat quantity or output of the heat source should be greater than the demand of the heat sink. Otherwise, an additional heat generator may have to cover the peak load.
- 3. Zeitlicher Verlauf von Abwärmefall und Wärmebedarf:** The better the match and time sequence of the heat source and heat sink, the greater the utilization of the heat source. The availability of waste heat should therefore correspond as closely as possible to the demand profile of the waste heat sink. Heat storage systems can be used if there is a time lag between heat availability and heat consumption.

Other relevant factors include the distance between the heat source and the heat sink (investment costs), the space required for the technical equipment, and ensuring the security of the supply of the waste heat sink (backup supply or redundancy solution may be required).

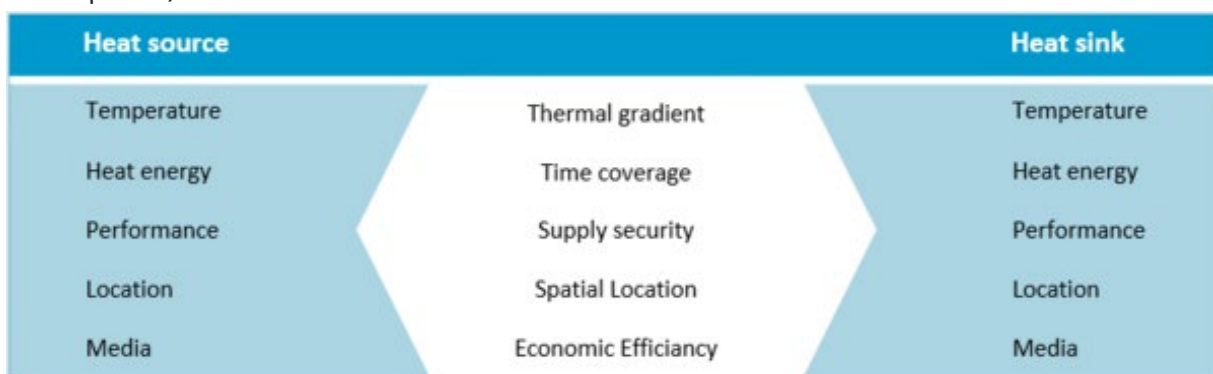

In-house waste heat utilization

Suppose waste heat is used internally in a process or plant. In that case, this is done either directly via a heat exchanger or indirectly by feeding it into a plant-internal steam network. If certain conditions are met, then heat pump technology is also an option.

1. Waste heat utilization via heat exchanger

The utilization of waste heat through heat exchangers is usually the simplest and most cost-effective option from a technical point of view. A heat exchanger is worth considering in almost all cases where unused heat energy is produced as a "waste product" in order to increase the efficiency of the overall plant.

Heat exchangers make waste heat usable for processes at a similar or lower temperature level. They transfer the thermal energy of a medium (gas or liquid) to a medium of lower temperature without the two media touching or mixing. For this purpose, the warmer medium transfers its energy to the colder medium via the heat exchanger surface, which largely determines the performance of the apparatus.

Heat exchanger design criteria

Choosing the appropriate heat transfer technology depends on a variety of factors:

- State of aggregation of the waste heat and process medium (liquid/liquid, gaseous/liquid, gaseous/gaseous)
- Phase transition (evaporation or condensation of one or both media).
- Pressure level and pressure difference between the media.
- Contaminated media require designs that are less susceptible to fouling and easy to clean.
- Corrosive, aggressive or hazardous media may require specific materials or special designs.

There are a wide variety of designs adapted for the processes. For example, a heat exchanger that condenses extracted steam requires a different format than a heat exchanger that cools down a process condensate.

2. Feeding into the plant's internal steam network

Large mills in the pulp industry supply a wide variety of consumers via complex steam networks. For example, suppose sufficient waste heat with a temperature of well over 150 degrees celsius is generated at one point in the process. In that case, installing a steam generator to feed the waste heat into the mill energy network is an obvious solution.

Most plants already use internal cycle closure to reduce the use of primary steam. As a result, almost all waste heat with a temperature level of over 140 °C is reused internally.

3. Heat utilization using industrial heat pumps

Heat pumps represent an efficiency-enhancing technology that will gain significant importance in the coming years. Their application can significantly reduce the use of fossil energy sources to provide process heat by boosting process waste heat to usable temperature levels and thus enabling it to be fed back into the processes (e.g., as process steam).

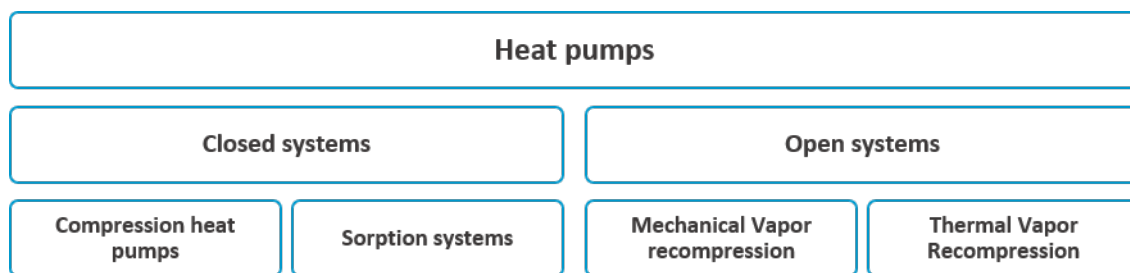

Focus is on low temperature waste heat

Low-temperature streams that cannot be used directly in heat exchangers are particularly relevant for waste heat utilization by heat pumps.

Potential areas for their use in the pulp and paper industry are mainly washing and drying processes and evaporation and distillation. Low-temperature waste heat can also be fed into a local or district heating network as an alternative.

Mechanical vapor recompression in the pulp industry

Mechanical vapor recompressors are primarily used in the pulp industry as they are considered superior to other types of heat pumps in terms of efficiency and economy. Vapor compressors are open heat pump systems that do not have a refrigerant circuit.

Instead, the gaseous waste heat medium is drawn in by a compressor and raised directly to a higher temperature level by increasing the pressure. The field of application covers all thermal separation processes.

For chemical recovery in both the sulfite and sulfate processes, the technology is used to raise the process steam (vapor) generated during caustic evaporation to a higher temperature and thus higher energy level and then fed back into the process as working steam.

The energy required to create live steam is considerably higher by comparison. Mechanical vapor recompression has proved particularly successful for projects which increases the existing plants' performance and pre-evaporation.



External use: From waste heat to local and district heating

If no suitable users are found within the pulp mill, waste heat can be sold to third parties via low-temperature heat networks rather than being destroyed. Another option is to take over peak loads in district heating networks, mainly where plant operators handle their own energy supply.

1. Decoupling to heat networks offers high flexibility

Local and district heating networks have the advantage of using a large number of different heat sources flexibly, which can be both centralized and decentralized.

- The heat network takes in different energy sources at different levels and points, regardless of summer or winter.
- So whatever waste heat is generated and is economically viable in the pulp mill can be extracted and profitably fed into the heating network.

As a result, the company saves cooling water costs, generates income from the sale of heat energy, and also makes an essential contribution to reducing CO₂ emissions, as the heat fed in would otherwise have to be generated elsewhere.

2. Complexity requires comprehensive potential analysis

The majority of pulp mills in Europe have grown historically and expanded over time. Consequently, each mill is unique with its specifics, operating points, and feeds. In addition, energy use is very complex, and specific energy consumption varies widely among pulp mills.

Therefore, each plant must be analyzed comprehensively to evaluate the waste heat potential. Then, once it has been cleared which energy surpluses need to be extracted on the process side, the heat exchangers can be optimized according to the boundary parameters..

3. Large heat pumps as a promising technology for the future

Pulp processes frequently generate waste heat below the 50 to 70 degree celsius temperature spectrum and are therefore not suitable for low-temperature district heating networks. In the coming years, large heat pumps will become increasingly common for utilizing such energy sources.

Large heat pumps are a cost-effective way of integrating previously unused waste heat into internal processes as well as local and district heating networks.

- They extract thermal energy from waste heat sources at a comparatively low-temperature level and make it available to the local or community heating network at a higher temperature level.
- Open systems similar to vapor recompression or closed systems with an auxiliary medium are used.
- Even waste heat below 50 degrees celsius still offers a considerable temperature level and can be raised to a low-pressure steam level with heat pumps based on a multistage compressor system at a reasonable cost.

Heat pumps are technologically advanced and operate reliably, efficiently, and economically. Today, the most significant challenge no longer lies in the heat pump technology but in the optimal design and integration of the heat pump into the overall system.

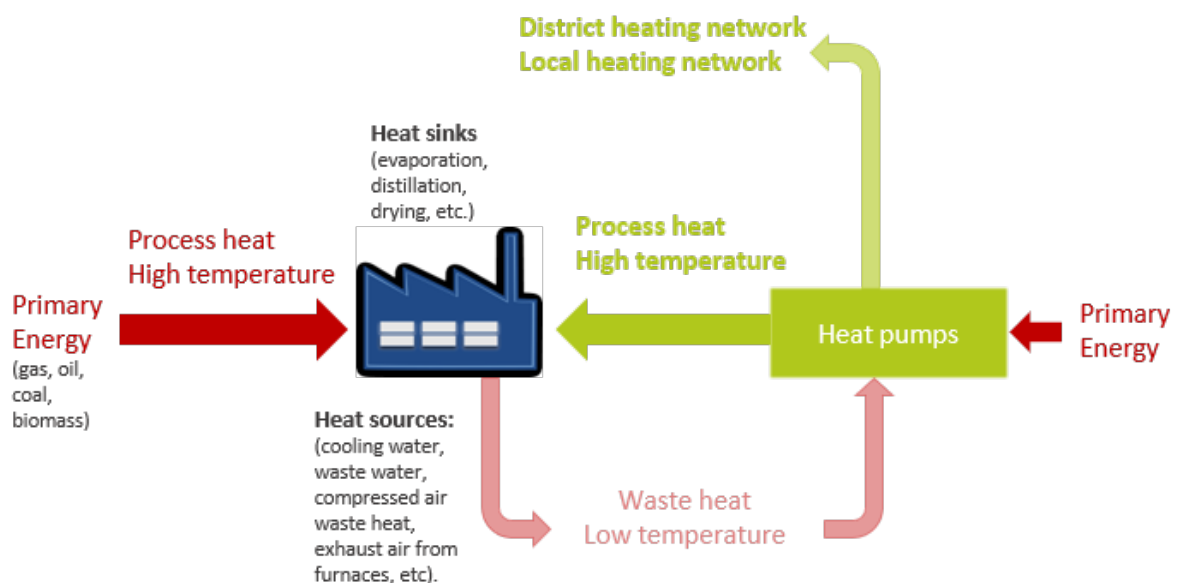

4. Maximum efficiency with compression heat pumps

Electrically driven compression heat pumps are crucial in local and district heat extraction as efficient heat transformers. In contrast to vapor compressors with an open circuit, compression heat pumps have a closed system that operates according to the cold vapor principle and is driven by a mechanical compressor:

- 1. The heat exchanger (evaporator):** By adding waste heat, the auxiliary medium (refrigerant) is evaporated due to the low boiling temperature.
- 2. Compressor:** The refrigerant in the compressor is brought to a condensing pressure and temperature.
- 3. Condenser/liqefier:** Condenser/liqefier: The auxiliary medium releases the heat via a heat exchanger and condenses in the condenser.
- 4. Expansion valve:** The condensate is decompressed, causing the auxiliary medium to liquefy completely again and the temperature to drop below the level of the waste heat. This allows heat transfer from the waste heat to the refrigerant.

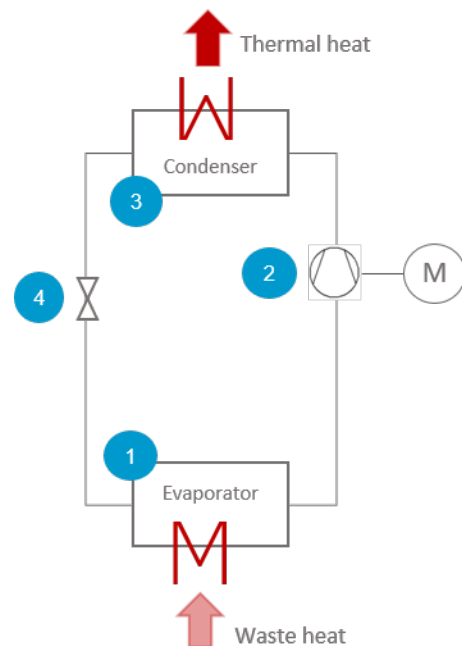

Conclusion: Industrial waste heat utilization in the pulp industry

In addition to measures taken to reduce energy consumption, waste heat utilization is one of the company's most profitable ways of minimizing energy consumption through the appropriate plant technology. In particular, vapor recompression and large-scale heat pumps are becoming increasingly important and, together with energy extraction in local and district heating networks, will be increasingly used in the coming years.

In the pulp industry, GIG Karasek has a high level of expertise in analyzing and evaluating waste heat flows and their potential utilization. In addition, we have many years of experience in integrating heat recovery systems in pulp mills and manufacturing the necessary equipment..

Our experts are available
for an in-depth analysis of your specific requirements
and for any initial expert advice!



**Schedule an appointment
with our experts now!**



GIG Karasek GmbH
Neusiedlerstrasse 15-19
A-2640 Gloggnitz
☎ +43 / 2662 / 42780
office@gigkarasek.at

www.gigkarasek.com